

# PowerTech™ 6135AFM85 Diesel Engine

Marine Propulsion Engine Specifications

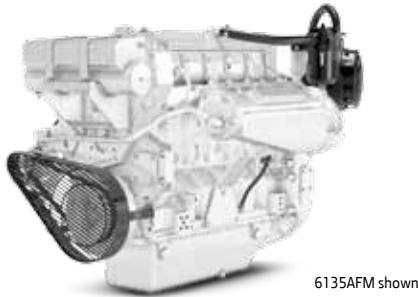

## Dimensions

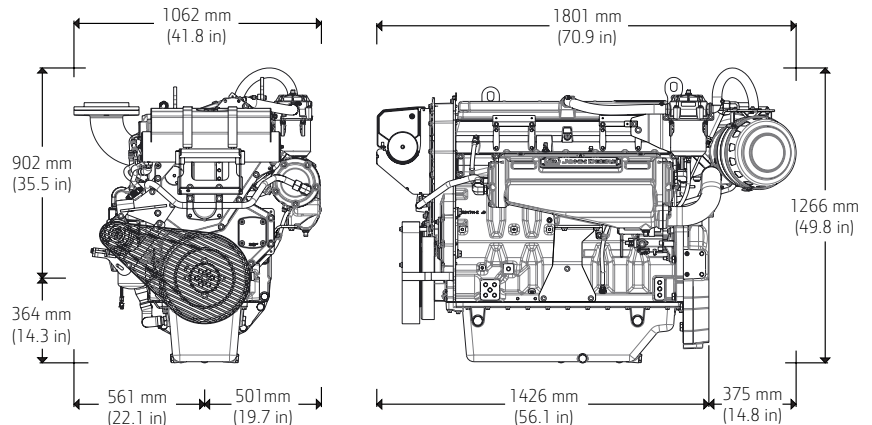

Dimensions shown in mm (in) may vary according to options selected.  
Contact your distributor for more information.

## Emissions

EPA Commercial Marine Tier 3  
IMO MARPOL Annex VI Compliant  
NRMM (97/68/EC), as amended

## General Data (based on standards option configuration)

Model	6135AFM85
Number of cylinders	6
Displacement – L(cu in)	13.5 (824)
Bore and Stroke – mm (in)	132 x 165 (5.2 x 6.5)
Engine Type	In-line, 4-cycle
Aspiration	Turbocharged and air-to-coolant aftercooled

Length maximum – mm (in)	1801 (70.9)
Length to rear face of flywheel housing – mm (in)	1426 (56.1)
Flywheel housing SAE	SAE #1
Width maximum – mm (in)	1062 (41.8)
Crankshaft centerline left – mm (in)	561 (22.1)
Crankshaft centerline right – mm (in)	501 (19.7)
Height – mm (in)	1266 (49.8)
Height, crankshaft centerline to top – mm (in)	902 (35.5)
Height, crankshaft centerline to bottom – mm (in)	364 (14.3)
Weight, dry – kg (lb)	1410 (3108)

## Classification Societies

SOLAS – Accessories available\*  
ABS, DNV, BV, LR

\*Other accessories available. Contact your distributor for details.

## Engine Specifications

Performance ratings	Power kW (bhp)	Rated Speed (rpm)	Rated fuel consumption L/hr (gal/hr)
M1	272 (365)	1800	76.7 (20.3)
M2	317 (425)	1900	86.2 (22.8)
M3	373 (500)	2000	102 (27.0)
M4	429 (575)	2100	119 (31.4)

Metric hp = Brake hp x 1.01387

M rating	M1	M2	M3	M4
Typical load factor	>65%	<=65%	<=50%	<=40%
Typical Annual Usage (hr)	Unrestricted	3,000-5,000	2,000-4,000	1,000-3,000
Typical full-power operation (hr)	Uninterrupted	16 of each 24 hr	4 of each 12 hr	1 of each 12 hr

Ratings are based on ISO 8655 standard power rating and the SAE J1228 crankshaft power rating.

Flexibility of installation due to range of options

See your John Deere Power Systems engine distributor or marine dealer for more detailed performance information.

## Features and Benefits

### High-torque and low rated RPM

- High torque provides excellent vessel control and maneuverability
- Lower rated propulsion RPM reduces vibration and noise for improved crew comfort

### Electronic unit injectors (EUI)

- The EUI fuel system provides higher injection pressures
- Controls fuel injection timing and provides precise control for start, duration, and end of injection

### Replaceable cylinder liners

- Replaceable wet-type cylinder liners are precision-machined and hardened for long life
- Allows engine to be rebuilt to original specifications

### Multiple service options

- Either-side oil fill/dipstick combinations and remote oil and fuel filter options are available for easier service access

### 4-valve cylinder head

- Excellent airflow through 4-valve cylinder head delivers greater low-speed torque and better transient response time

### Water-cooled exhaust manifold

- Integrated components eliminate external hoses and fittings that can leak or break
- Wet exhaust manifold creates a cooler and quieter environment for passengers and crew

### Electronic engine control unit (ECU)

- Advanced fault code diagnostics and customizable engine protections ensure reliability and uptime
- Provides highly customizable features and trim to integrate your vessel

### Keel-cooled or heat exchanger

- Closed cooling system in keel-cooled engine option eliminates the need for a sea strainer, seawater pump, or anodes
- Heat exchanger option offers a lighter, more compact, and simpler engine installation

---

**John Deere Power Systems**  
3801 W. Ridgeway Ave.  
PO Box 5100  
Waterloo, IA 50704-5100  
Phone: 800.553.6446  
Fax: 319.292.5075

**John Deere Power Systems**  
**Usine de Saran**  
La Foulonnerie B.P. 11.13  
45401 Fleury les Aubrais Cedex  
France  
Phone: 33.2.38.82.61.19  
Fax: 33.2.38.82.60.00

*All values at rated speed and power with standard options unless otherwise noted. Specifications and design subject to change without notice.*